

QUALIFICATIONS:

- Meets all the requirements of UL 555 and CAN/ULC-S112.
- Meets the requirements for NFPA 80, 90A and 101, as well as IBC and NBC (Canada) building codes.
- California State Fire Marshal Listing No. 03225-0935:0113.
- City of New York Board of Standards and Appeals. Cal. No. 460-88-SA.

NOTES:

1. Installation shall be in accordance with the appropriate requirements of the National Fire Protection Association Standard NFPA 90A latest edition.
2. **Damper Sleeve:** Sleeve thickness must be equal to or thicker than the duct connected to it. Sleeve gauge requirements are listed in the SMACNA Fire, Smoke and Radiation Damper Installation Guide for HVAC Systems and in NFPA 90A. If a break-away style duct/sleeve connection is not used, damper sleeves up to 36" wide by 24" (914 x 610) high of not less than 16 gauge (1.61) coated steel, or larger sleeves of not less than 14 gauge (1.99) thick coated steel may be attached to the duct with screws or other types of mechanical fasteners. The maximum sleeve thickness for such rigid joints is 10 gauge (3.51) for coated steel. The connecting duct shall not be continuous thru the wall or floor opening but shall terminate at the sleeve. Sleeves shall extend a maximum of 6" (152) on either side of the wall or floor opening or 16" (406) on one side when incorporating a factory installed access door.

3. Break-away duct/sleeve connections:

- a. Rectangular ducts must use one or more of the following connections if the gauge is less than the requirement in note 2 for rigid connections:

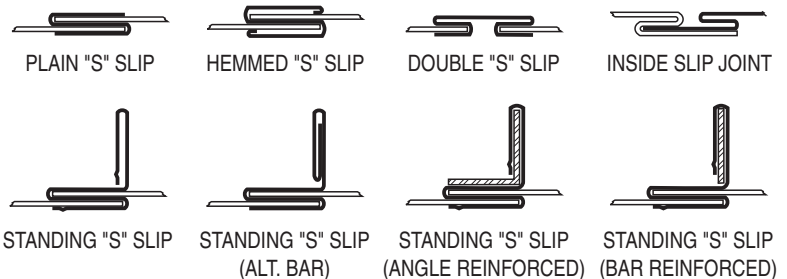

In addition:

- A maximum of two #10 sheet metal screws on each side and on the bottom, located in the center of the slip pocket and penetrating both sides of the slip pocket may be used.
- One of the above connections on the top and bottom joints with flat drive slip connections on the side joints may be used for dampers up to 20" (508) in height.



- b. Round and oval duct may be attached to the round or oval collar which is part of the damper/sleeve in the following manner:
 - Duct diameters 22" (559) and smaller must use three #10 sheet metal screws equally spaced around the circumference.
 - Duct diameters over 22" (559) up to and including 36" (914) may use five #10 sheet metal screws equally spaced around the circumference.
 - Duct diameters larger than 36" (914) wide or diameter may use eight #10 sheet metal screws equally spaced around the circumference.

Dimensions are in inches (mm).

Note: When optional sealing of these break-away connections is desired, the duct sealant shall be PA2084T Duct Sealant by Precision or water based DP1010 by Design Polymetrics.

c. For the use of approved alternative Ductmate or TDC/TDF break-away connections, refer to the supplements noted on page 4.

4. Damper/sleeve attachment: Damper shall be secured to sleeve with 1/4" (6) long welds, spot welds, 3/16" (4.76) steel rivets, 1/4" (6.35) dia. bolts and nuts, #8 sheet metal screws, or 3/16" (4.76) dia. buttonlocks on both sides at 6" (152) on center and a maximum of 2" (51) from the corners of the damper on all four sides. For field assembled sleeves, the inner dimensions of the sleeve shall be equal to the outer dimensions of the damper.

5. Retaining angles shall be a minimum of 1 1/2" x 1 1/2" x 16 gauge (38 x 38 x 1.61) for dampers up to 90" (2286) in width and up to 90" (2286) in height. For dampers exceeding these dimensions, the angles shall be a minimum of 2" x 2" x 10 gauge (51 x 51 x 3.51). Secure the retaining angles to the sleeve with 1/2" (12.7) long welds, 1/4" (6.35) dia. bolts and nuts, 3/16" (4.76) dia. steel rivets or #8 sheet metal screws 8" (203) on center and 2" (51) maximum from corner of sleeve on all four sides. The retaining angles must lap the structural opening by 1" (25.4) minimum. When the ductwork terminates at the wall or floor, the retaining angles may be turned inwards, providing the opening size is increased by an amount equal to twice the combined thickness of the angle and the height of the screw or bolthead to maintain the required expansion clearance. Field fabricated retaining angles are not to be mechanically fastened at the corners.

6. Expansion clearance between the sleeve and wall or floor shall be a minimum of 1/8" per foot (3.18 per 305) of width or height of the sleeve. The maximum size of the opening shall be 2" (50.8) larger in either dimension than the allowable minimum size. For example; a sleeve dimension of 36" x 36" (914 x 914) shall have an opening size of 36 3/8" x 36 3/8" (924 x 924) minimum and 38 3/8" x 38 3/8" (975 x 975) maximum.

7. The maximum Type A fire damper sizes are as follows:

Model Series				Single Section	Multiple Section
0100	Static	Vertical	(1 1/2 hr. label)	60" x 60" (1524 x 1524)	120" x 120" (3048 x 3048)
		Horizontal	(1 1/2 hr. label)	60" x 60" (1524 x 1524)	102" x 60" (2591 x 1524) **
0300	Static	Vertical	(1 1/2 hr. label)	60" x 48" (1524 x 1219)	—
		Horizontal	(1 1/2 hr. label)	48" x 48" (1219 x 1219)	—
D0100	Dynamic	Vertical	(1 1/2 hr. label)	36" x 36" (914 x 914)	36" x 48" (914 x 1219) OR **** 72" x 24" (1829 x 610)
		Horizontal	(1 1/2 hr. label)	24" x 24" (610 x 610)	—
0500	Static	Vertical	(3 hr. label)	48" x 48" (1219 x 1219)	108" x 72" (2743 x 1829) ***
		Horizontal	(3 hr. label)	36" x 36" (914 x 914)	72" x 36" (1829 x 914)
0540	Static	Vertical	(3 hr. label)	60" x 48" (1524 x 1219) or 24" x 60" (610 x 1524)	—
		Horizontal	(3 hr. label)	24" x 24" (610 x 610)	—
D0500	Dynamic	Vertical	(3 hr. label)	36" x 36" (914 x 914)	36" x 48" (914 x 1219) OR **** 72" x 24" (1829 x 610)
		Horizontal	(3 hr. label)	24" x 24" (610 x 610)	—

* Type B and C dampers have the same overall damper size but the connecting ducts are smaller due to the B or C enclosures. See Type B and Type C specification drawings for maximum duct sizes.

** Maximum individual sections not to exceed 34" x 60" (864 x 1524).

*** Maximum individual sections not to exceed 36" x 36" (914 x 914).

**** Maximum individual sections not to exceed 24" x 24" (610 x 610), up to 48" x 24" (1219 x 610). Assemblies larger than 48" x 24" (1219 x 610) will be made up of individual sections not to exceed 18" x 24" (457 x 610).

8. Multiple Section Assemblies. Individual dampers may be joined together to make multiple section damper assemblies (see Figure 1). The frames shall be fastened together using 1/4" (6) long welds, 3/16" (4.76) steel rivets, 1/4" (6.35) bolts and nuts, #8 sheet metal screws or 3/16" (4.76) buttonlocks on both sides of the damper at 6" (152) max. on center and 2" (51) max. from the corner of the damper on all 4 sides. The following additional requirements shall be met:

Vertical dampers, 1 1/2 hr. label over 84" (2134) in width require a 12 ga. x 4 1/4" (2.75 x 108) wide steel mullion plate placed between adjacent vertical damper frames and the frames fastened together through this with 1/4" (6.35) bolts and nuts, 12" (305) max. on center. Dampers over 84" (2134) in height require a full length 2" x 2" x 10 ga. (51 x 51 x 3.51) steel angle bolted along horizontal joints on both sides of the assembly using 1/4" (6.35) bolts and nuts, 12" (305) max. on center (see Figure 2).

Horizontal dampers, 1 1/2 hr. label over 84" (2134) wide require a 14 ga. x 4 1/4" (1.99 x 108) wide steel mullion plate placed between adjacent damper frames and the frames fastened together through this using 1/4" (6.35) bolts and nuts, 1/4" (6) long welds or #8 sheet metal screws, 4" (102) max. on center.

Vertical dampers, 3 hr. label multiple sections require a 16 ga. x 6" (1.61 ga. x 152) wide "Z" mullion with 7/8" (22) flanges shall be placed between any horizontal joints (see Figure 3). The frames shall be joined together using 3/16" (4.76) bolts and nuts, 1/4" (6) long welds or #8 sheet metal screws, 6" (152) max. on center.

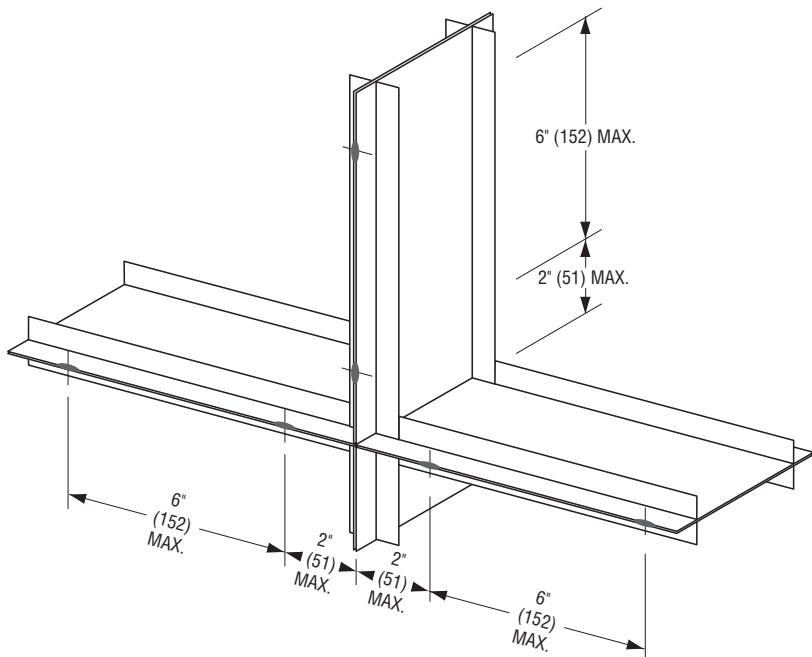

Figure 1.
Fastening of damper frames (see note 8).

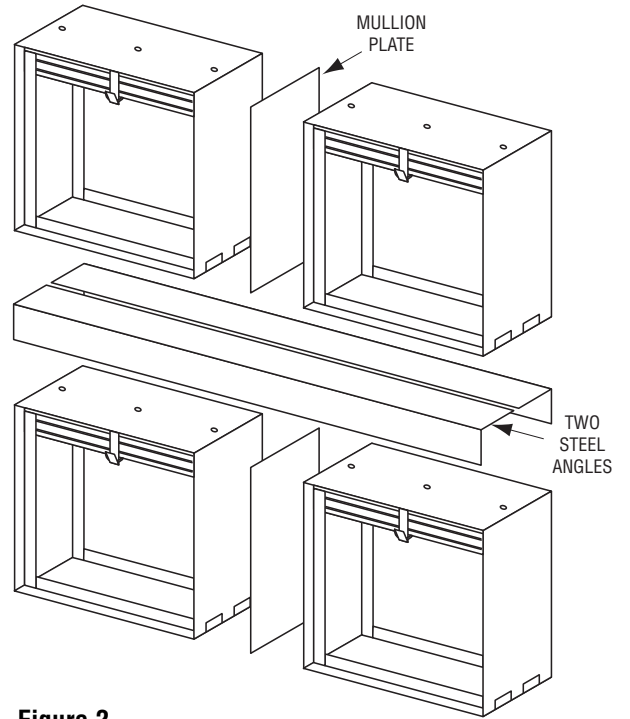

Figure 2.
1 1/2 hr. label vertical installation
over 84" x 84" (2134 x 2134) (see note 8).

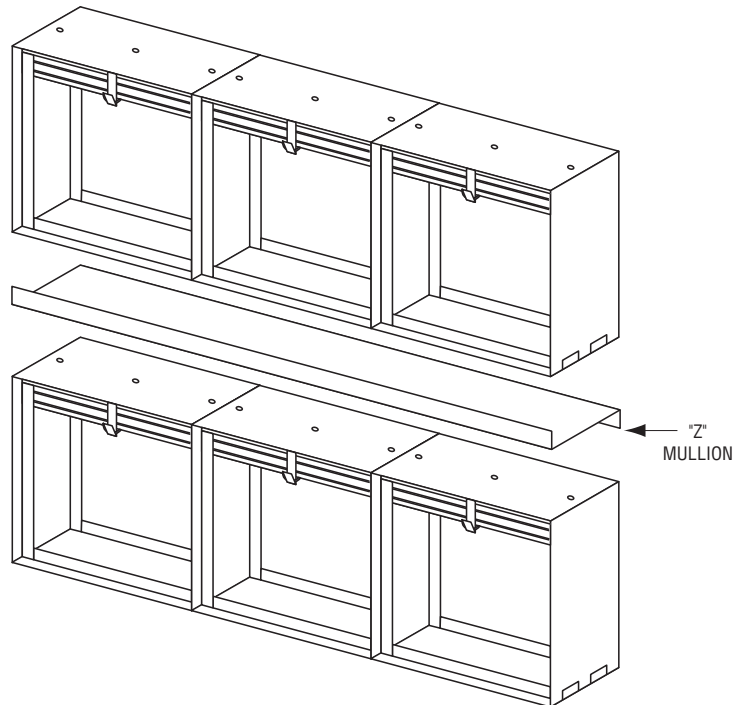

Figure 3.
3 hr. label vertical installation multiple section (see note 8).

9. In cases where the openings are larger than specified in note 7, a UL tested and qualified steel mullion must be provided between assemblies (refer to supplementary installation sheet FDSMINST).

IMPORTANT

DO NOT CAST DAMPER IN PLACE.
DO NOT FASTEN RETAINING ANGLES OR DAMPER DIRECTLY TO WALL OR FLOOR.
DO NOT INSTALL DAMPER OUT OF SQUARE OR OUT OF FLAT.
VERTICAL MOUNTING SHOWN ON MASONRY WALL.
FOR INSTALLATION IN DRYWALL FRAMING, SEE DOC. FDSWSFINST.
HORIZONTAL MOUNTING SIMILAR FOR MASONRY FLOOR.

REFER TO THE APPROPRIATE NAILOR INSTALLATION INSTRUCTION SUPPLEMENTS FOR THE FOLLOWING SPECIAL REQUIREMENTS:

STEEL MULLIONS (for dampers in oversized wall openings)	FDSMINST
SINGLE SIDED RETAINING ANGLES	FDSSRAINST
STEEL AND WOOD STUD FRAMING	FDSWSFINST
CAVITY SHAFT WALL PARTITIONS	FDCSWINST
FLANGED TYPE ALTERNATIVE BREAKAWAY CONNECTIONS	FDFABC
TDC/TDF FLANGED DUCT CONNECTION	FDTDCFINST
QUICK-SET RETAINING ANGLES	FDQSRA

Dimensions are in inches (mm).

Page 4 of 4



Houston, Texas
Tel: 281-590-1172
Fax: 281-590-3086

Las Vegas, Nevada
Tel: 702-648-5400
Fax: 702-638-0400

Toronto, Canada
Tel: 416-744-3300
Fax: 416-744-3360

Calgary, Canada
Tel: 403-279-8619
Fax: 403-279-5035